

# Electro-Hyd. Circuit - JumboZ-1500E PTO with Joystick Control

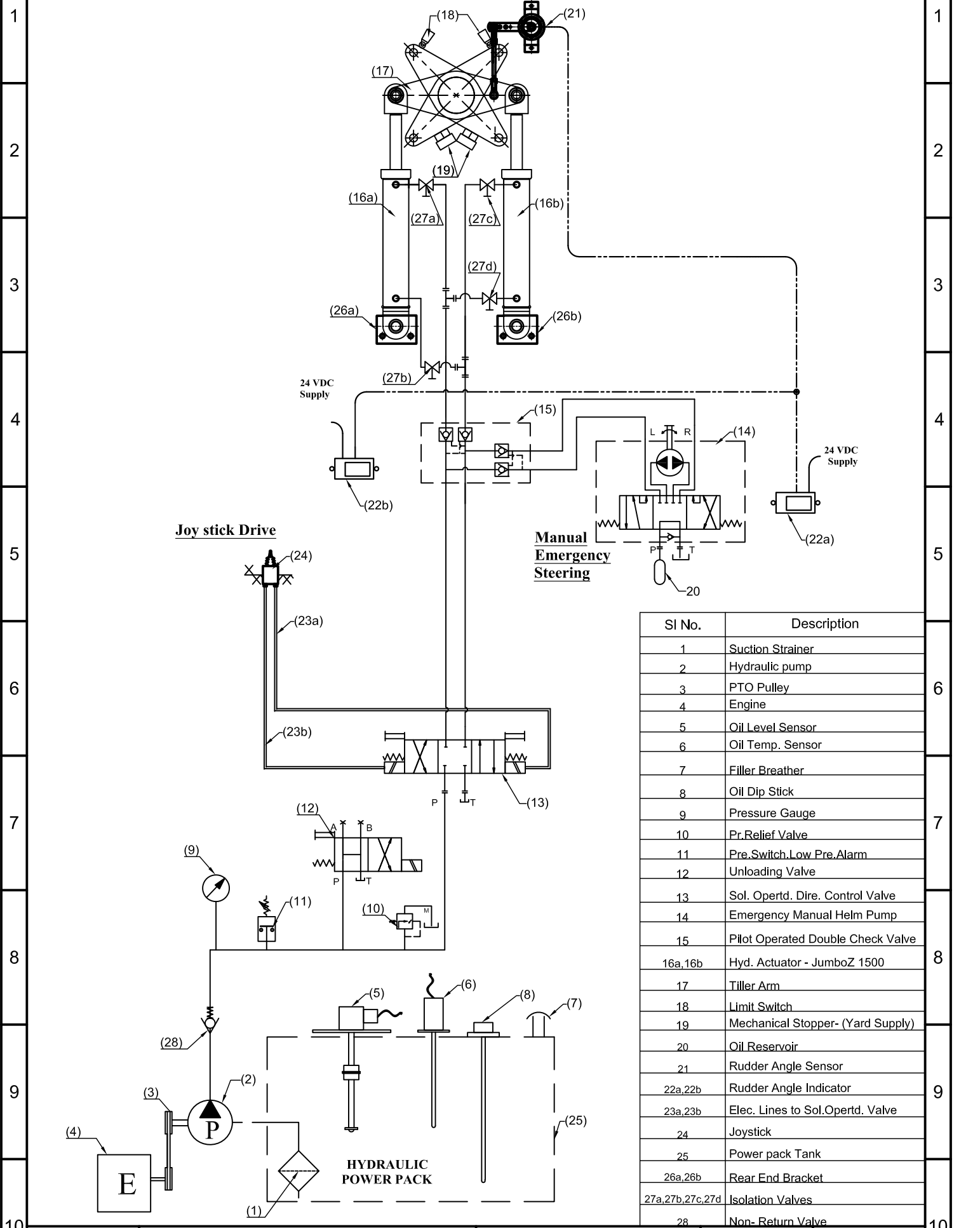

Sl No.	Description
1	Suction Strainer
2	Hydraulic pump
3	PTO Pulley
4	Engine
5	Oil Level Sensor
6	Oil Temp. Sensor
7	Filler Breather
8	Oil Dip Stick
9	Pressure Gauge
10	Pr. Relief Valve
11	Pre. Switch. Low Pre. Alarm
12	Unloading Valve
13	Sol. Opertd. Dire. Control Valve
14	Emergency Manual Helm Pump
15	Pilot Operated Double Check Valve
16a,16b	Hyd. Actuator - JumboZ 1500
17	Tiller Arm
18	Limit Switch
19	Mechanical Stopper- (Yard Supply)
20	Oil Reservoir
21	Rudder Angle Sensor
22a,22b	Rudder Angle Indicator
23a,23b	Elec. Lines to Sol. Opertd. Valve
24	Joystick
25	Power pack Tank
26a,26b	Rear End Bracket
27a,27b,27c,27d	Isolation Valves
28	Non- Return Valve